



THE HERO TWINS:
BLOOD RACE

BY RAMÓN ESQUIVEL

THE
PARAMOUNT
THEATRE



The University of Texas at Austin
Theatre and Dance
College of Fine Arts

ABOUT THE PLAY

OUR STORY

THE HERO TWINS: Blood Race tells the story of **Moth** and **Cricket**, twins in the **Freed** tribe. We follow the twins as they navigate a world where the **Privileged** tribe is given many advantages over them. We see them tackle the **Blood Race**, an ancient tradition that must be run by our heroes in order to change the world.

This is an original story imagined by the playwright, Ramón Esquivel. The world of the play is inspired by the politics and culture of Classic Mayan society, and influenced by Mayan mythology recorded in the Popol Vuh, a text of the history and myths of the K'iche' people of Guatemala. The Hero Twins of this play, Moth and Cricket, are homages to two pairs of Hero Twins in Mayan and Navajo indigenous mythologies.

OUR INVITATION TO YOU

This is a PLAY, and we'd like to invite you to be playful with us. If it seems fun to you, please:

Cheer for your favorite characters!

Yell at characters that are behaving badly.

Clap, slap, hum, and sing along with the show!

In many times, in many places, theater has been performed during festivals and parties. Unfortunately, not too long ago, many theaters near us started asking audiences to act more like students in a quiet library instead of party-goers. Our favorite part of performing *THE HERO TWINS* is that we get to perform the show with YOU! The more energy you send toward the actors the better they will become. Go ahead, be playful. That's why we are here!

—*THE HERO TWINS* Actors and Directors



MEET THE PLAYWRIGHT

Ramón Esquivel is a playwright and educator based in the Pacific Northwest. His play *Luna* was produced at the University of Texas at Austin in 2017, and toured Austin area schools. *Luna*, *Nasty*, and *Nocturnal* are published through Dramatic Publishing, and his work is featured in two recent anthologies. He currently teaches playwriting and theatre education at Central Washington University.

“What I hope young people learn from these two characters is the different responses they can have to challenge and adversity. Nobody is perfect, but when Moth and Cricket work together they can accomplish far more than when they’re working on their own. I want to encourage young people to ask questions about inequality in today’s society. Why do some people have more than others? THE HERO TWINS is a gateway to talking about our own society.”

“Theatre is designed to be experienced more than read. There’s something about an audience experiencing a story together, laughing together and potentially crying together, that bonds them.”

—Ramón Esquivel

DIRECTOR'S NOTE:

“As the director I believe it is my job to guide the actors and designers to discover our vision of this play together. Creativity, encouragement, and trust helps people find the best version of their idea. There is a play only this unique group can make - my job is to help us find it and share it.”

—Will Kiley



EXPLORING FAIRNESS

EXPLODING ATOM ACTIVITY

Begin by standing in a circle. Read the below statements. If you agree with the statement, step towards the center. If you disagree, step away from the center. Take turns sharing why you chose to stand in a certain area. Remember: there is no right or wrong answer; this activity is meant to help you express an opinion.

All people are treated fairly.

Consider: What does "fair" mean?

Everyone deserves the same opportunities.

Consider: What happens when people don't get the same opportunities?

Working together can accomplish more than working alone.

Consider: When might this be true and not true?

It is more important to be fair than it is to be just.

Consider: How are "fair" and "just" related?

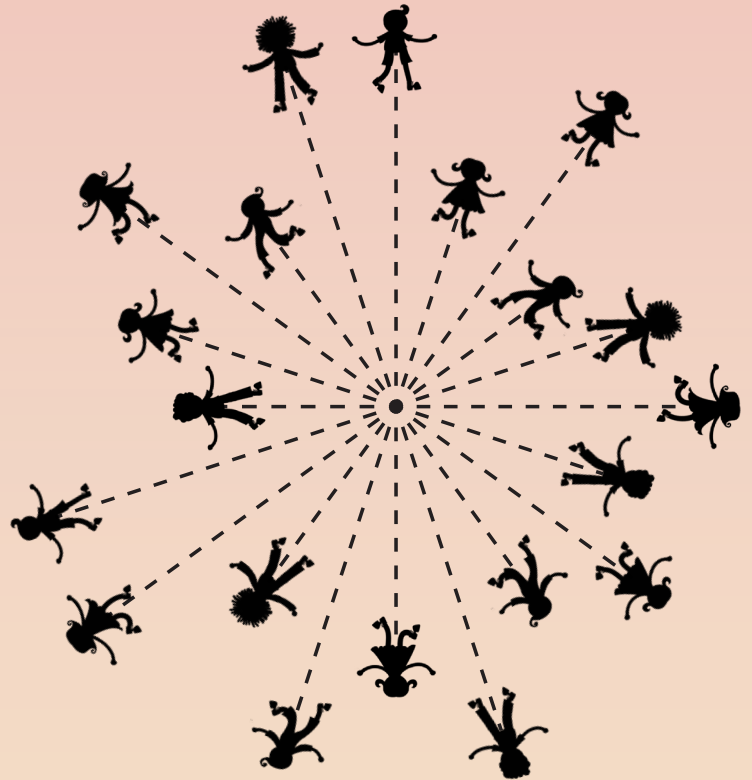

What did it feel like to participate in this activity? _____

When did we disagree the most? _____

When did we agree the most? _____

What did we learn about each other? _____

MAIZIE'S MAZES

Maizie, a corn husk doll, is Cricket's favorite gift from his parents. Complete Maizie's mazes and notice how your process is different for each one. If you were being timed, can you imagine having a harder maze while your friend got the easy one? Is that fair? Is that just?



Indigeneous tribes made dolls like Maizie from the husk of a corn cob, or maize.

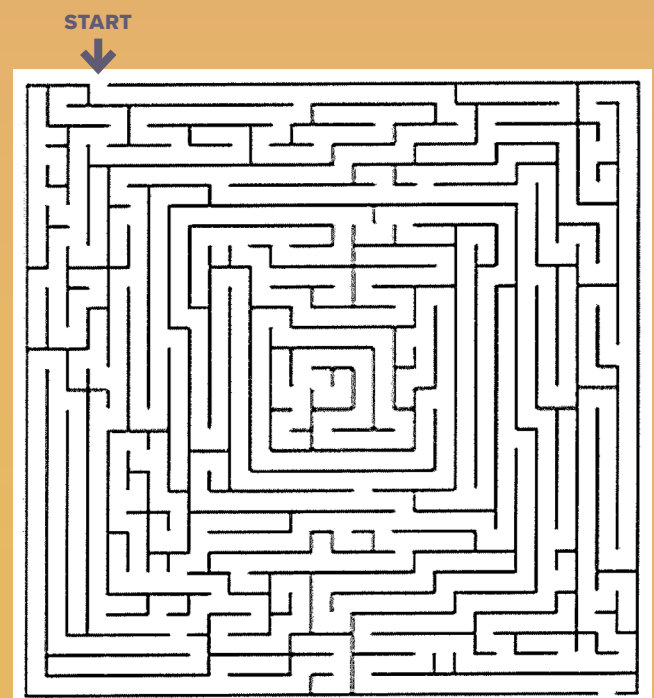
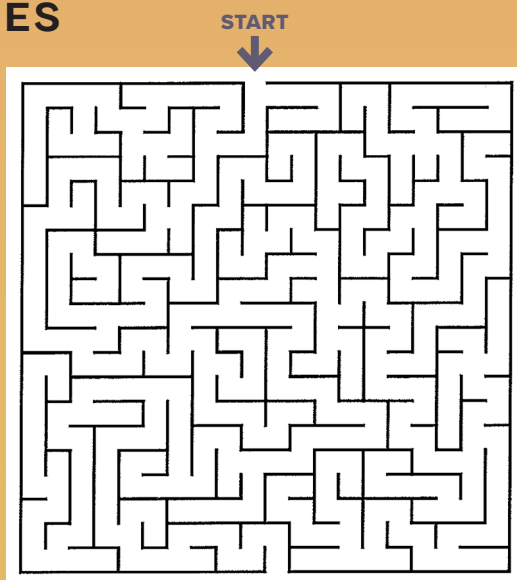

THE HERO'S JOURNEY

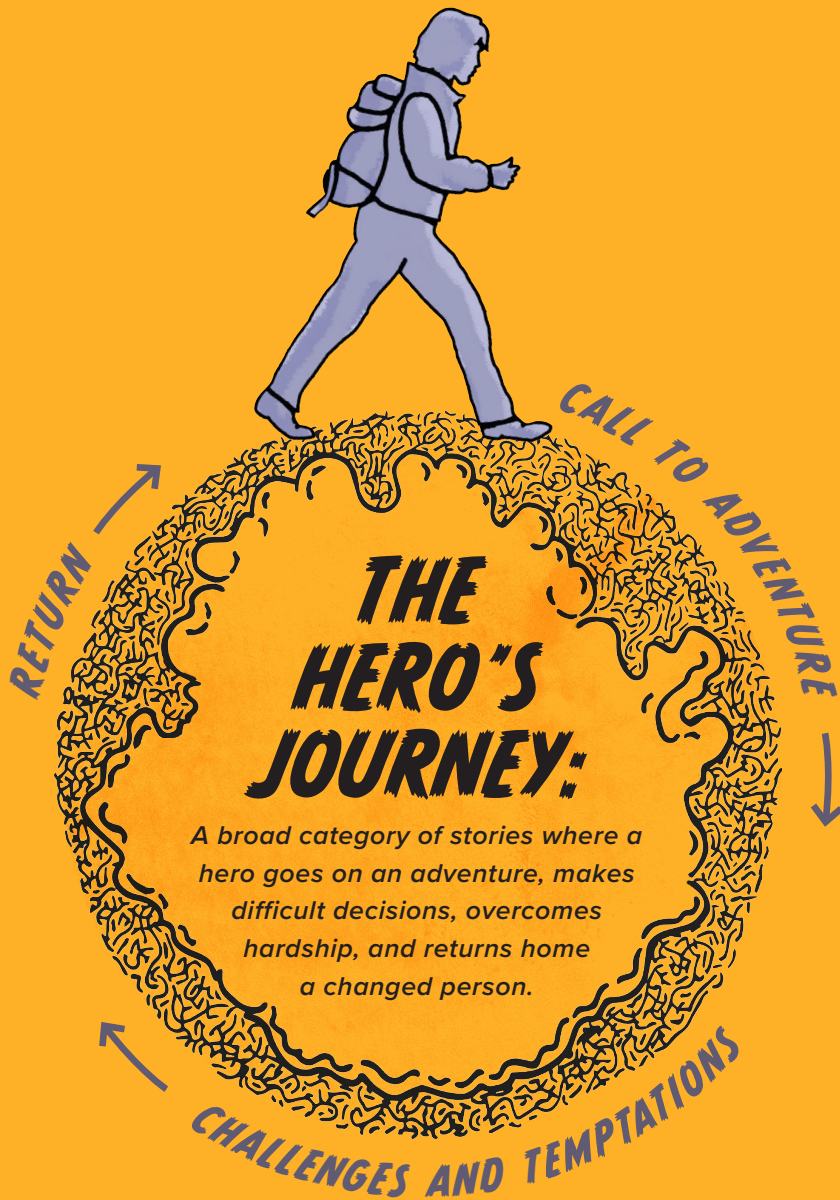

Below each description of the stages of The Hero's Journey, write examples from *THE HERO TWINS: Blood Race* or another story you know.

STAGE 1: The hero is called to adventure at the beginning of the story, venturing from the known to the unknown. The hero begins a transformation!

STAGE 2: The hero encounters challenges and temptations. Here the hero learns how to overcome. There may be help from a mentor.

STAGE 3: The hero returns to their home having accomplished their goal. They have had a revelation and/or discovered more about themselves through their journey.

The plot of *THE HERO TWINS: Blood Race* was inspired by the legends of the Navajo and Mayan Hero Twins:

NAVAJO HERO TWINS

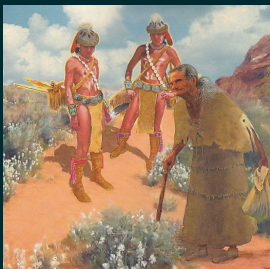

In the Navajo legend, twin brothers Monster Slayer and Born From Water (sons of WhiteShell Woman and the Sun) face challenges in their journey to rid the world of alien gods who wish to do harm. Along the way, the twins encounter various other Holy People that help them in their journey, who give

them gifts and sacred items to protect them. Their will is tested by their father, the Sun, and they must slay the Big Giant who drank all the water; they spread the flint from his armor across the world so the people on Earth may use it.

MAYAN HERO TWINS



In the Mayan legend, twin brothers, Hunahpu and Xbalanque, are born to one of the original divine hero twins and Xquic, a daughter of the Underworld lords. Their father and uncle were tricked by the lords of the Underworld and lost their lives, so the new hero twins visited the Underworld to

avenge their father and uncle. They outsmarted the tricks and traps set by the Lord of Death and conquered his games. They became the rulers of the Earth, one became the Moon, and the other became the Sun.

ABOUT THE CHARACTERS

On stage you'll meet the incredible characters of *THE HERO TWINS: Blood Race*. The characters are played by student actors from the University of Texas at Austin Department of Theatre and Dance. Each of the actors shared a quote from the play that best describes their characters. Be sure to look out for these lines of dialogue during the play!

GECKO (Audrey Loomis)
"Will you tell the story?"

CRICKET (Gilberto Beltran)
"First we people. Give learning. Run together."

JAGUAR (Adrian Nanez)
"The truth is what we say it is."

MAQAB
(Phoebe Osbourne)
"So what do you choose?"

MOTH
(Natasha Batista)
"We free us."

IGUANA
(Anapaula Guajardo)
"I am the first woman to be a high priest."



THE TRIBES

Spirit:
Maqab

Privileged:
Iguana, Jaguar, Gecko

Freed People:
Moth, Cricket

Which character can you relate to and why?

MOTH: A nocturnal insect similar to a butterfly, but lacks the clubbed antennae of butterflies and typically has a stout body, drab coloration, and wings that fold flat when resting.



WHOSE TEAM ARE YOU ON?

If you were running a race with one of these characters whose team would you want to be on? (*circle one*)

MOTH

JAGUAR

What qualities would you want in your team members? (*Examples from our cast: trust, loyalty*)

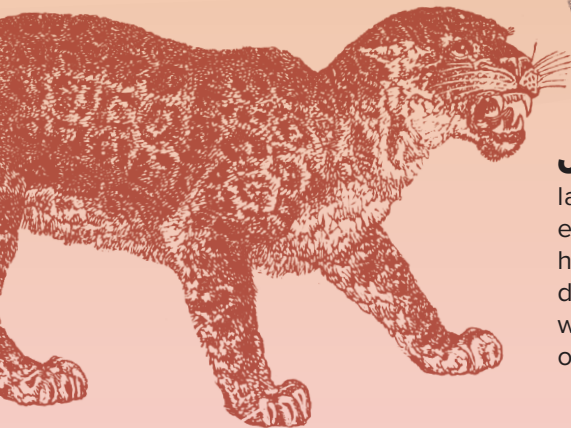

JAGUAR: A very large cat that can run in excess of 64 miles per hour or 103 KM over short distances. Usually the cat will be running to catch prey or to escape a larger threat.



THE WORLD OF THE PLAY

In *THE HERO TWINS*, the characters live in three different worlds. Life looks very different in each one. Read the descriptions about them in the pyramid below, then write words and create drawings of what you imagine each one to be like.

OVERWORLD

MIDDLE WORLD

OVERWORLD

The Spirits and Guardians live in the Overworld. They live in a beautiful location with an abundance of resources like food and nice clothing.

MIDDLE WORLD

The people of the Freed tribe and Privileged tribe live in the Middleworld. You can find the Cave that Moth and Cricket live in, as well as the capital called The Temple of the Blood Steps.

UNDERWORLD

The underworld holds the deepest and darkest caverns – all the obstacles for the Blood Race. You can find Razor, Ice, and Fire Cavern as well as the Victor's Chamber. And if you look closely, maybe hidden knowledge.

UNDERWORLD

Based on what you know about these three worlds, where would you want to live and why?

Which characters in the play do you think have the most power based on where they live?

THEATRE DESIGN

WHAT'S INVOLVED

Costuming helps audiences understand the culture of the world through clothing.

Props create all hand-held items used during the play, called props.

Scenery creates the physical set that invites audiences into what the world looks like.

Lighting sets the mood by using light to create different effects.

Designers present sketches at initial meetings, then through creative collaboration, the costumes, props, set, and lighting are developed in relationship to each other. The goal is for the designers to bring their ideas together so the play looks unified and follows the director's vision.

The caverns in *THE HERO TWINS* are a single set with movable pylons (also called pillars) that represent Stone, Ice, and Fire.

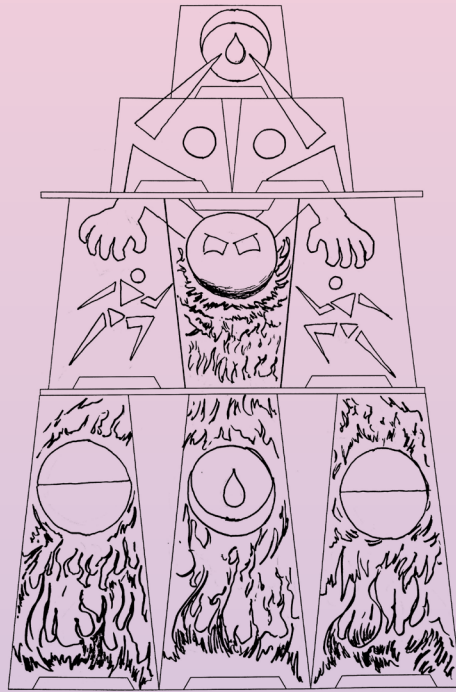

Be a scenic designer! Draw your own cavern on our template below:

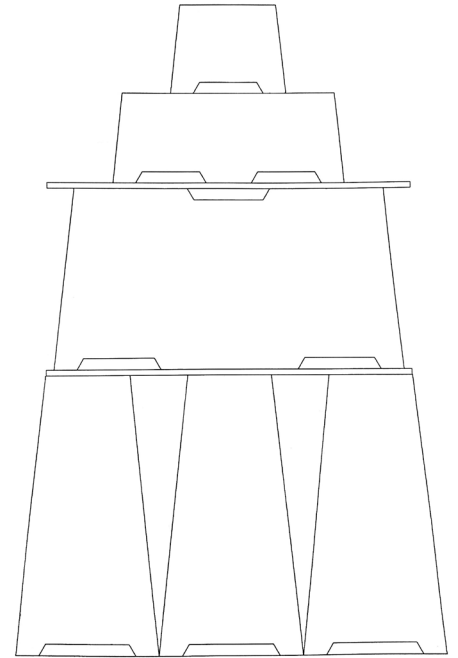

UNDERSTANDING FRICTION

The scenic designers for *THE HERO TWINS* spent a lot of time considering how the actors would use momentum and friction to run, jump and climb on the set. **Friction** is the action of one surface or object rubbing up against another. How do you think friction might affect Moth's movement through the ice cavern? Try out the experiments below to find out!



WILL IT SLIDE?

Materials: Ice cube and a glass or ceramic plate

Moth states that *"ice has little friction, so if I had a good momentum, the ice wouldn't change direction as I slid across it."* Place the ice cube on the plate and give it one push across. The goal is to get the ice cube to go in a straight line with just the one push. Is it possible? (circle one)

YES

NO

Pick up the plate and rotate it around, moving the ice without touching it. How easy or hard is it to move the ice?

Why do you think so?

SLIPPERY WHEN WET

Often times if something is slippery it means that there is less friction between the item and the surface it's placed on. Test these items below and circle the ones that are slippery:

ICE

RUBBING HANDS TOGETHER

WASHING YOUR HANDS

SOCKS SLIDING ON A HARD FLOOR

SHOES SLIDING ON A HARD FLOOR

Which of these two experiments do you think has more friction involved, and why?

FORBIDDEN KNOWLEDGE

SYMBOLS TO COMMUNICATE

THE HERO TWINS: Blood Race created original symbols to use both on our set and in our costumes, and they're also how the characters communicate with each other. The symbols' meaning is hidden from some people in the story and forbidden to learn. In our show you will get to see how important it is to understand this secret language.



THE MAYAN ALPHABET



The original symbols you will see in the play are based on the written Mayan language. There were around 800 symbols in written Mayan, more than an alphabetic writing system like English or a syllabic system like Japanese katakana.

OUR SECRET CODE

On the bottom of pages 1 and 4, we left you a secret message in our own alphabet. Just like the characters in the show, you may not have known there was hidden information. Go back and decode the message!

What was it like to look at the symbols at first and not know what they meant?

How did it feel to gain this secret knowledge?

A	B	C	D	E	F
G	H	I	K	L	M
N	O	P	R	S	T
U	V	W	Y	Z	

Write your own secret message with our alphabet below. Swap messages with a friend!

In the play, there are symbols that represent characters' names. If you made a symbol to represent your name, what would it look like?

CELESTIAL BODIES

SUN, MOON, OR ECLIPSE?

The below sentences describe either the sun, moon, or an eclipse. Circle one answer for each, then check your answers upside-down at the bottom of the page!

- | | | | |
|---|------------|-------------|----------------|
| 1. A large natural object that orbits something other than a star. | SUN | MOON | ECLIPSE |
| 2. A star at the center of our solar system. | SUN | MOON | ECLIPSE |
| 3. Its gravitational pull causes the majority of the earth's tides. | SUN | MOON | ECLIPSE |
| 4. The total or partial obscuring of one celestial body by another. | SUN | MOON | ECLIPSE |
| 5. About one million Earths would fit inside of this. | SUN | MOON | ECLIPSE |
| 6. It takes eight minutes for its light to reach Earth. | SUN | MOON | ECLIPSE |
| 7. Has craters that are caused by asteroids and comets. | SUN | MOON | ECLIPSE |

SOLAR ECLIPSE: when the moon passes exactly in front of the sun and casts a shadow on Earth.

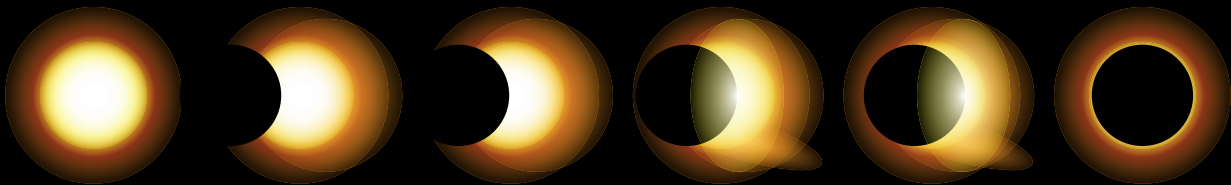

LUNAR ECLIPSE: when Earth passes between the sun and moon, and the moon is hidden in Earth's shadow.

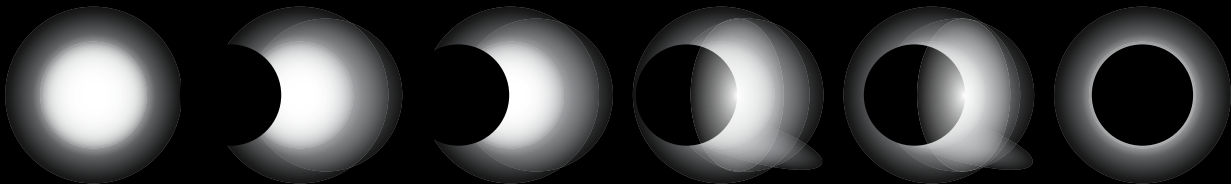

BLOOD MOON

When four total lunar eclipses happen within the span of two years, the fourth one is a blood moon. In *THE HERO TWINS*, every time a blood moon happens, the Blood Race happens, a runner chosen from two tribes and made to run a race through three caverns.

MAKE YOUR OWN ECLIPSE

Materials: Flashlight, Orange, Bouncy ball ¼ the size of the orange

- Put the orange and ball on a table, in a line, about 8 inches apart.
- Stand about 2 feet away from the table. Hold the flashlight at the same level as the clay and the orange, then shine the light from behind the clay ball.
- Check out the shadow on the orange.

What celestial bodies do each of these objects represent?

FLASHLIGHT

ORANGE

BALL

ARTIFACTS OF MEMORY

MEMORY STONES

The Hero Twins use memory stones to remember their parents. The stones are covered in pictures or symbols that represent them. What would your family or friends' memory stones look like? Draw on the blank stones below and write who each one represents:



Person:

Person:

Person:



Person:

Person:

Person:

PERSONAL ARTIFACTS

The Hero Twins, Moth and Cricket, have objects or artifacts like a corn doll or chisel that represent who they are. Draw an object or artifact represents you:

GOALS

Many of the characters in *THE HERO TWINS* have important goals for themselves. Iguana is the first female high priestess. Moth hopes to win the Blood Race. What do you hope to accomplish in your life?

RESOURCES

CULTURAL STUDIES

Learn more about the Navajo people, and the Navajo Hero Twins: navajopeople.org/blog/navajo-winter-storytelling-poster

Learn more about the Mayan Hero Twins: www.thoughtco.com/hunahpu-xbalanque-maya-hero-twins-171590

Learn about how the Indigenous Cultures Institute in San Marcos is preserving the cultures of Native Americans in Texas and northern Mexico: www.indigenoucultures.org

SCIENCE

What is a blood moon? www.timeanddate.com/eclipse/blood-moon.html

Learn more about momentum and friction: www.physics4kids.com/files/motion_friction.html

THEATRE

Teachers, look for more drama-based activities to reflect on the play: dbp.theatredance.utexas.edu

Learn more about our playwright and Latinx Theatre for Young Audiences: howlround.com/latinx-theatre-young-audiences

Learn more about The University of Texas Department of Theatre and Dance: theatredance.utexas.edu



The University of Texas at Austin
Theatre and Dance
College of Fine Arts

The Department of Theatre and Dance is a world-class educational environment that services as the ultimate creative incubator for the next generation of artists, thinkers and leaders in theatre and performance.

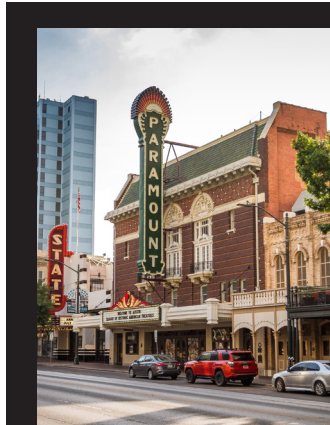

THE PARAMOUNT THEATRE is in downtown Austin on Congress Avenue. It is on the National Register of Historic Places in Texas! It was built 104 years ago in 1915. The Paramount has been bringing Austin families together for generations through the power of the arts. We hope to see you there soon!

DISCOVERY SERIES

THEATRE FOR FAMILIES

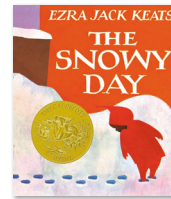

Make unforgettable memories at the Paramount Theatre with your whole family. Tickets and subscriptions are available now! Visit:

austintheatre.org/discovery

PARAMOUNT EDUCATION

We inspire the intellect and imagination of young people by providing opportunities to **experience, perform, and learn** through the arts. We can't wait to see you again at our theatre or in our school programs! Paramount Education programs are made possible through generous donations from our community. If you are interested in finding out more or want to make a contribution, please reach out to Natalie Seeboth at nseeboth@austintheatre.org or 512.233.0121. Thank you!

THANK YOU TO OUR 2019-2020 EDUCATION PARTNERS



Alice Kleberg Reynolds Foundation

Sear Family Foundation

Cielo Azul Foundation

The Speedwell Foundation

ECG Foundation

Stark Martin Charitable Trust

ED Foundation

Summer Learning Investment Hub

Georgia B. Lucas Foundation Fund of The Austin Community Foundation

SXSW Community Fund

The Powell Foundation

Wayne and Joann Moore Charitable Foundation

The Reese Foundation

The Wright Family Foundation

THANK YOU TO OUR 2019-2020 SEASON PARTNERS



PARAMOUNT
EDUCATION

Learn more about our education and family programs:
www.austintheatre.org/education

@ParamountEduATX

